



Mars-Energy

**Electronic DC Energy meter
KWH-MARSEN**



Equipment Certificate

MC2.720.500 EC

Edition 2

Russia
Saint Petersburg

Contents

| | |
|---|----|
| 1 Sphere of application | 3 |
| 2 Basic Specifications | 4 |
| 3 Scope of supply | 13 |
| 4 Design and operation principle | 13 |
| 5 Storage, transportation and warranty conditions | 15 |
| 6 Operation | 18 |
| 7. Maintenance and safety requirements | 24 |
| 8. Calibration procedure | 24 |
| 9. Acceptance form | 26 |
| 10. Packing form..... | 26 |

1 Sphere of application

1.1 The KWH-Marsen meter (the meter below) is a DC energy meter designed for use in on-train railway systems, traction substations and other transport systems for metering of either energy consumption (forward flow) or energy consumption and generation (forward and reverse flow) provided that no aggressive/hazardous gas or vapor present in the air.

1.2 As a nationally recognized tool, the meter has been registered under N 58638-14 with National Registry of measuring instruments and granted the Type Approval Certificate RU.C.34.001.A N 56973, by the Federal Agency on Technical Regulation and Metrology (Rosstandart). The Certificate is valid from 29 September 2014 till 29 September 2019.

1.3 Indoor environmental conditions:

- Ambient temperature from minus 40 °C to plus 50 °C
- Functional within minus 50 °C to plus 60 °C temperature range
- Relative humidity up to 90 % at 35 °C
- Atmospheric pressure 60 to 106.7 kPa

1.4 With respect to shock resistance, the design is conventional; the meter is resistant to vibration (10 to 100 Hz with acceleration of up to 10m/s²) and to single strikes (2 to 20 ms with acceleration of up to 30 m/s²).

1.5 The meter is designed as a complete measurement system equipped with an external Calibrated Shunt (accuracy class 0.5) for current measurements and an internal voltage divider for voltage measurements.

1.5.1 Measurement current shunts available:

- External shunt with a 75mV output signal (standard supply; 5 to 7500A currents), or
- External shunt with a 150mV output signal (optional; 150 to 1500A currents)

The shunts are interchangeable.

1.5.2 Voltage measurements:

Depending on the internal voltage divider, design versions with respect to DC voltage measurements may be as follows: 100V, 400V, 600V, 800V, 1500V, and 3000V.

1.6. The meter can be powered:

- From the circuit under review (via the Power Supply Unit, PSU); except for the 100V design version that can be powered from the measured circuit directly.
- From an auxiliary DC or AC network:
 - 100V, 400V, 600V, and 800V design versions are powered directly
 - 1500V and 3000V versions are powered via an optional HV Galvanic Insulation Module
 - The 3000V, 300A design version is supplied with the PSU in a protection enclosure.

Equipment Certificate

1.7 Depending on the design version, the meter can be connected to the circuit under review:

- As a sink input device, when the shunt is connected in series with the “minus” conductor, e.g. when measuring consumption of train traction energy;
- As a source input device, when the shunt is connected in series with the “plus” conductor, e.g. when measuring energy consumed for train auxiliaries.

1.8 Options

On customer request, the meter rated at a voltage below 1500V can be powered from an auxiliary DC network (40...300V) or AC network (30...230V, 49...61 Hz).

On customer request, the meter can be powered from an auxiliary DC network (40...60V) or AC network (30...50V, 49...61 Hz), or from an auxiliary DC network (110±35V) via the Power Adapter.

When the customer selects powering the meter from an auxiliary network, the PSU is not included in the delivery package.

On customer request, the scope of supply may include an insulation laminate (“textolite”) mounting board. The dimensions of the board are given in Fig. 2.2.

1.9 Reading data

It is possible to read data from the meter via its communication ports only if the meter is powered from any of the sources mentioned above.

2 Basic Specifications

2.1 With respect to electric energy measurements, the meter comes in two versions related to 1.0 or 0.5 accuracy class and can be named as follows:

- KWH-MARSEN-1.0 (accuracy class 1.0)
- KWH-MARSEN-0.5 (accuracy class 0.5).

The overall accuracy of the whole measurement system depends on the accuracy of the current Shunt or current transformer (if used).

2.2 Energy readings are displayed on a Liquid Crystal Display (LCD). The readings can be displayed directly in kWh or with use of a numeric multiplier 10^n (where n is a positive integer).

Energy measurement units (kW•h) and the multiplier (if used) are specified on the front panel of the meter.

The LCD has at least 6 digit positions.

The meter has one voltage measurement input and two current measurement inputs.

Energy metering can be performed via two channels:

Channel 1: voltage is multiplied by current taken from the 1st input

Channel 2: voltage is multiplied by current taken from the 2nd input.

Each of the channels can be independently set for measurements either in energy consumption or in energy consumption/generation mode.

While in consumption/generation mode, the meter displays readings alternately considering energy flow direction. The readings are indicated as follows:

“1_” – energy consumption in Channel 1

“2_” – energy generation in Channel 1

“3_” – energy consumption in Channel 2

“4_” – energy generation in Channel 2

On customer request, the meter can be set for energy metering in Channel 1 only.

The data indication time of the battery powered LCD is at least six years, regardless of whether the meter was powered from a circuit under review or any auxiliary power source, or not.

The time of data storage in the meter’s non-volatile memory is at least 10 years.

2.3 With Calibrated Shunt 75-CS, the design versions of the meter with respect to the rated current may be as follows: 5; 50; 100; 150; 300; 500; 750; 1000; 1500; 2000; 3000; 4000; 5000; 6000; 7500 A.

With Calibrated Shunt 150-CS, the design versions of the meter with respect to the rated current: 150; 300; 500; 750; 1000; 1500 A.

The current inputs of the meter work independently of one another so they can be independently set for work with any of the above-mentioned shunts and for any of the rated currents.

Regarding rated voltages, the following options are available: 100; 400; 600; 800; 1500; 3000 V.

2.4 The power consumed by the parallel circuit of the meter does not exceed 0.4 W per each 100V of the rated voltage.

The power consumed by the series circuit of the meter at the rated current does not exceed 1 mW.

2.5 The power consumed by the PSU from the circuit under review does not exceed 5 W per each 100V of the rated voltage.

2.6 The power consumed by the meter from an auxiliary DC power supply circuit does not exceed 5 W. The active and apparent power consumed by the meter from an auxiliary AC power supply circuit does not exceed 4 W and 5 VA respectively.

2.7 The maximal value of current that can be applied to the meter does not exceed 150 % of the nominal current.

2.8 The maximal value of voltage that can be applied to the meter does not exceed 140 % of the nominal voltage.

2.9 The permissible values of the intrinsic component of the relative fundamental error of the meter (“measurement error” below) in the consumption and generation modes, in normal operation conditions and at a rated voltage do not exceed the values given in Table 2.1.

Table 2.1

| Current, % of the rated current | Permissible limits of measurement error for the meter (accuracy class 1.0), % | Permissible limits of measurement error for the meter (accuracy class 0.5), % |
|---------------------------------|---|---|
| 5 | ± 6.0 | ± 4.0 |
| 10 | ± 3.0 | ± 2.0 |
| 20 | ± 2.0 | ± 1.0 |
| From 50 to 150 (inclusive) | ± 1.0 | ± 0.5 |

2.10 Sensitivity threshold

The value of current at which the register mechanism of the meter accepts pulses does not exceed 1% of the rated current (at the rated voltage applied, for both consumption and generation modes).

2.11 Creep

In the absence of load current and at a voltage of 60%, 100% and 140% of the rated voltage, 1 pulse (as a maximum) is accepted by the register mechanism of the meter.

2.12 The pulse input of the meter is an “open collector” input.

Voltage of the external PSU is 5...24 V (12V typically).

The value of the ballast resistor is determined by the typical value of current in the line in its active state (10 mA).

E.g., for the PSU rated at 12V, a 1.2 kOhm (0.25 W) resistor will be suitable.

Additional specifications of the pulse input:

The relation between the amount of energy registered by the meter and the number of pulses on its pulse output, known as “meter constant”, is expressed in imp/kWh. The value of the meter constant is selected on the basis that the frequency of the output pulse sequence takes a value of 100 Hz on applying the rated values of voltage and current. Pulse duration is 0.5 ms.

An actual value of the meter constant is specified on the front panel of the meter.

There is a LED indicator on the front panel that blinks synchronously with pulses on the pulse output.

The 2-channel meter has two pulse outputs and two LEDs (the left one corresponds to Channel 1, and the right one – to Channel 2).

2.13 The resistance of insulation between the entire circuitry of the meter or PSU and metal outside components of their enclosures is:

- 40 MOhm (at least, for the meter rated at a voltage of 1000V or less)
- 60 MOhm (at least, for the meter rated at 1500V)
- 100 MOhm (at least, for the meter rated at 3000V)

2.14 The insulation between the entire circuitry of the meter, or PSU, or Power Adapter and metal outside components of their enclosures provides for withstanding sinusoidal AC test voltage of RMS values indicated below during 1 min:

- 3 kV (50 Hz, for the meter rated at a voltage of 1000V or less)
- 9.5 kV (50 Hz, for the meter rated at 1500V and 3000V)

2.15 The insulation between the entire circuitry of the meter, or PSU, or Power Adapter and metal outside components of their enclosures provides for withstanding DC test voltage of 10 kV (for either polarity) during 1 min.

2.16 The insulation between the circuits of pulse outputs and interface ports connected together and other circuitry of the meter connected to the metal components of the meter's enclosure provides for withstanding DC test voltage of 6 kV (either polarity) during 1 min and sinusoidal AC test voltage 4 kV (RMS, 50 Hz) during 1 min.

2.17 The insulation between the input circuitry of the Power Adapter and its output circuitry provides for withstanding DC test voltage of 10 kV (for either polarity) during 1 min and sinusoidal AC test voltage of 9.5 kV (RMS), 50 Hz during 1 min..

2.18 For the meter powered from an auxiliary AC or DC power supply circuit, the insulation between the input circuitry of the meter and its power supply circuit provides for withstanding sinusoidal AC test signal 3kV (RMS), 50 Hz for 1 min.

2.19 The accuracy of the built-in clock is ± 0.5 s/24 hours across the entire operation range of the meter.

2.20 The weight of:

- KWH-Marsen meter does not exceed 1.5 kg
- KWH-Marsen meter installed on the mounting board – 2.8 kg
- PSU, design versions 3000/65 V and 1500/65 V – 2.0 kg
- PSU in the protection enclosure – 3.5 kg
- PSU, design versions 800/65 V, 600/65 V and 400/65 V – 1.0 kg
- Power adapter – 0.4 kg

2.21 The overall and mounting dimensions of the KWH-Marsen meter, PSU and Power Adapter are given in Fig. 2.1 – 2.6.

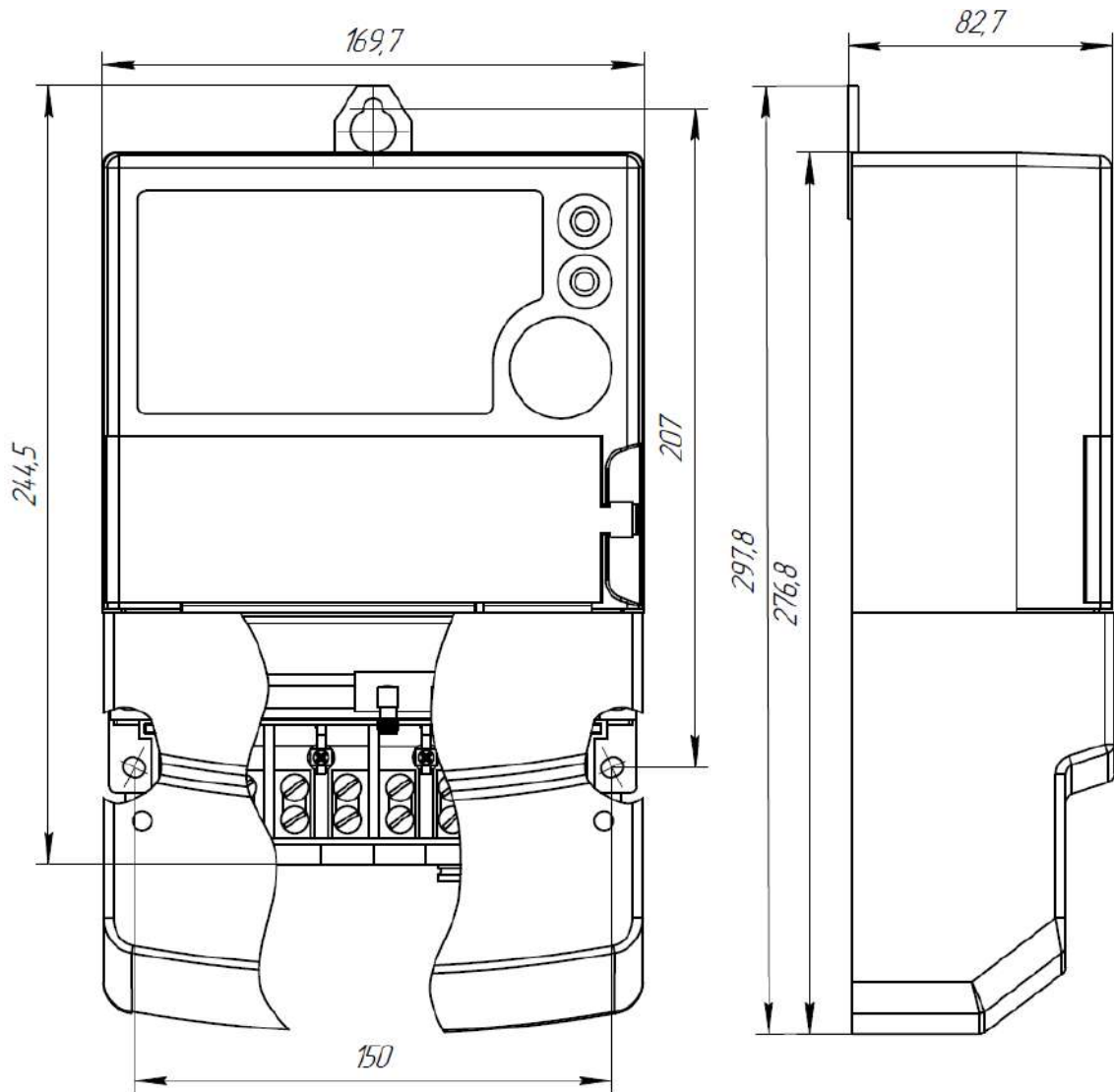

Fig 2.1 – Overall and mounting dimensions of the meter

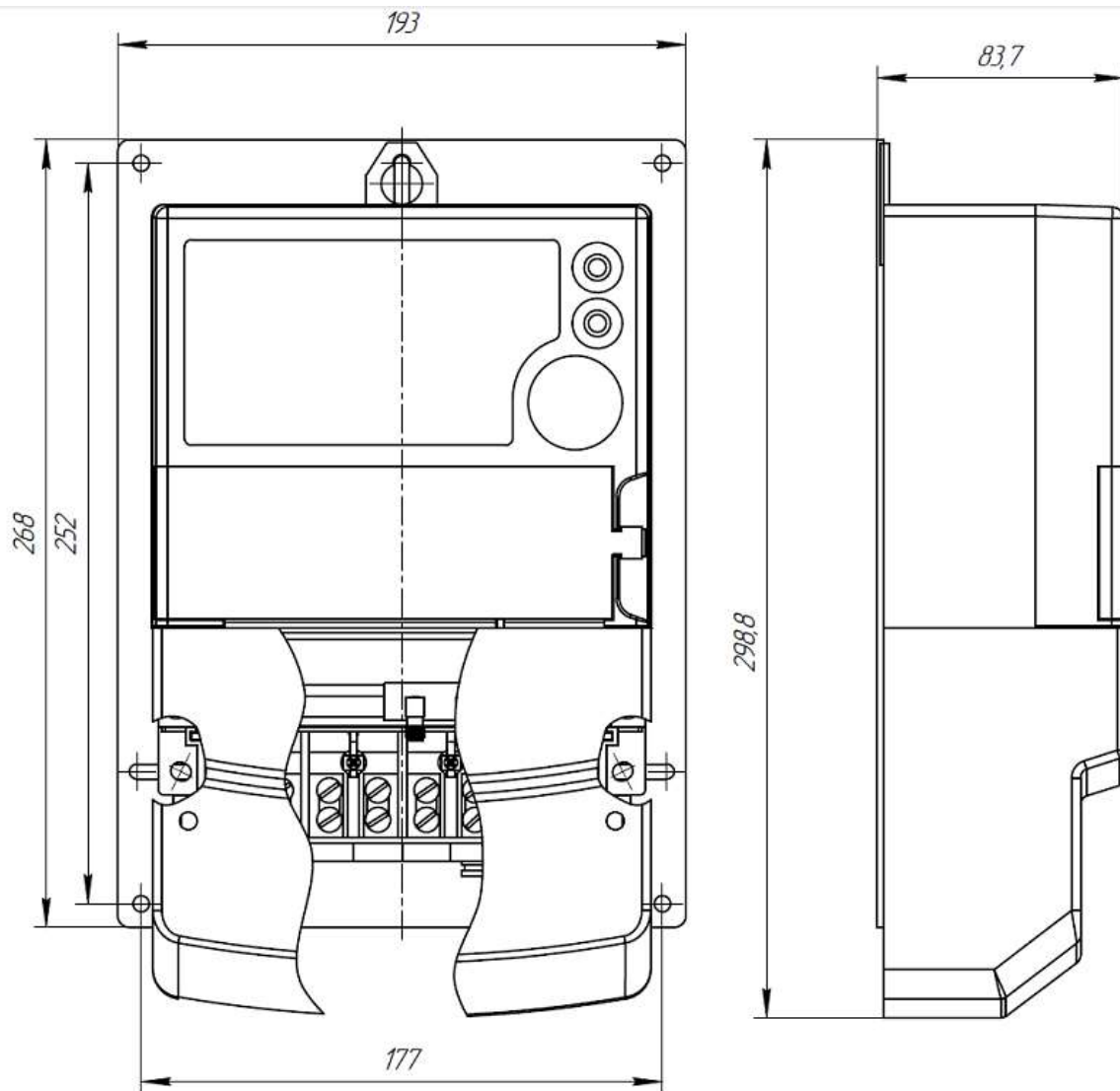

Fig. 2.2 – Overall and mounting dimensions of the meter installed on the mounting board

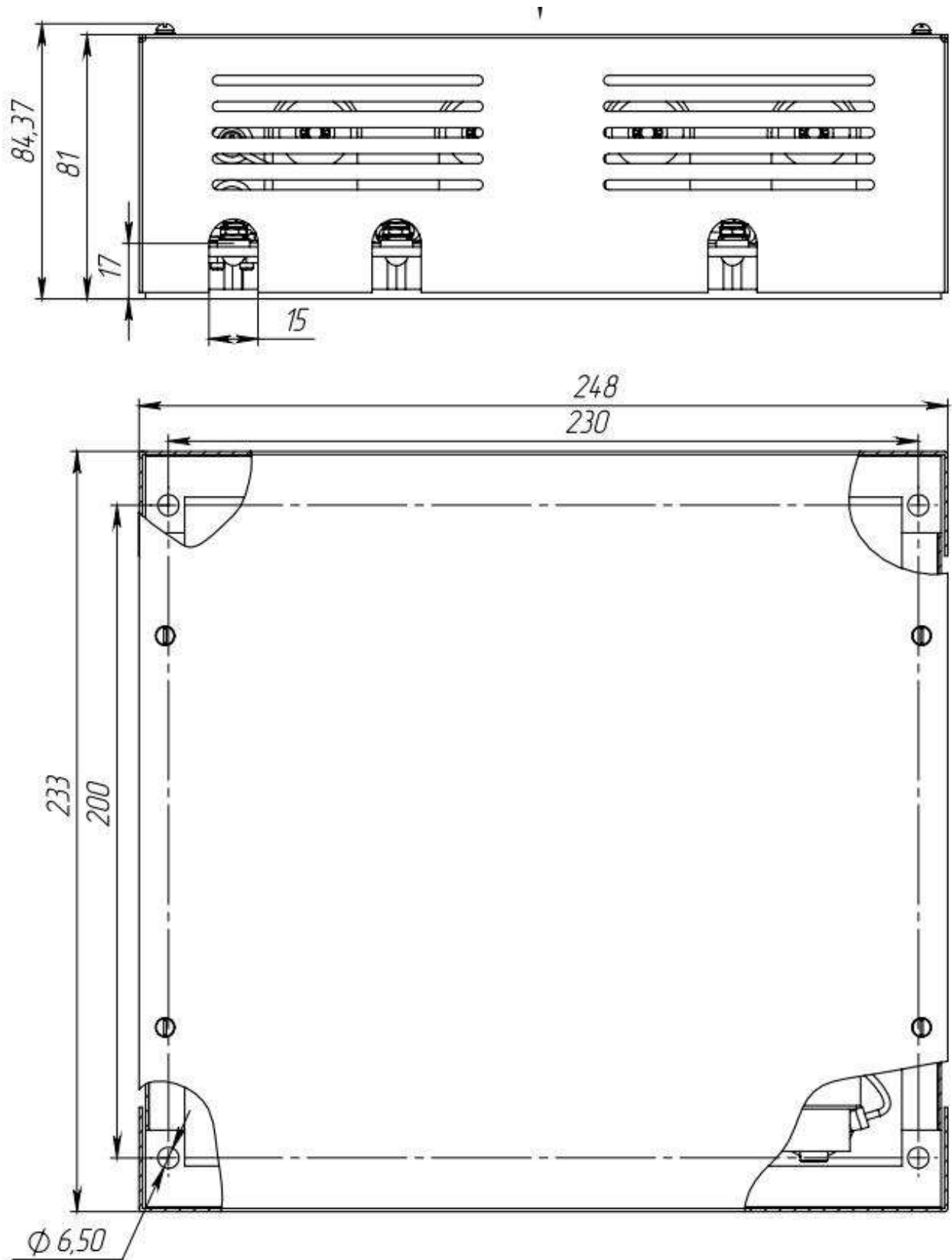

Fig. 2.3 – Overall and mounting dimensions of PSU, design versions 3000/65 V and 1500/65 V

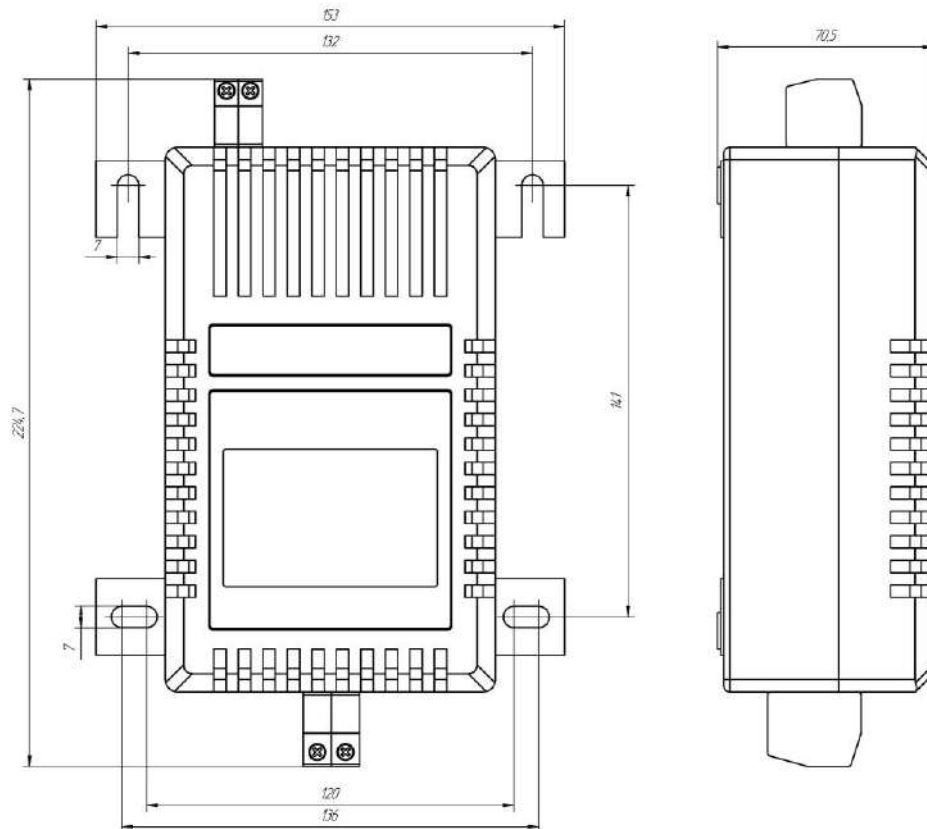

Fig. 2.4 – Overall and mounting dimensions of PSU, design versions 800/65 V, 600/65 V and 400/65 V

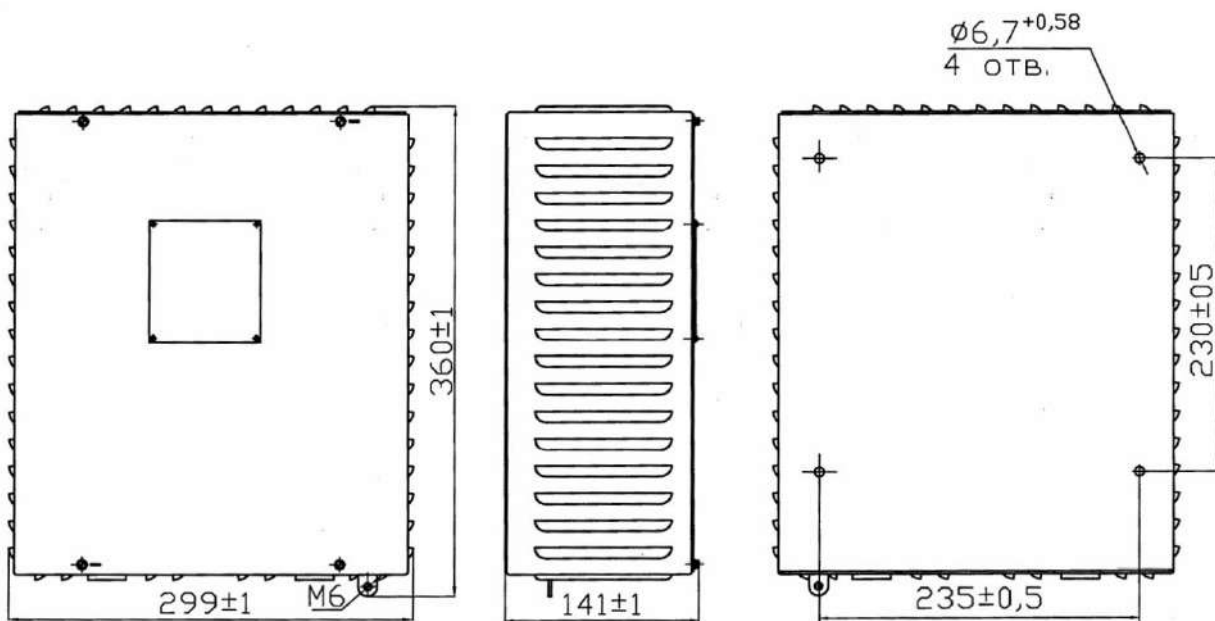

Fig. 2.5 – Overall and mounting dimensions of PSU 3000/65 V in the protection enclosure for the meter rated at 3000 V, 300 A (connected as a “sink” device)

Equipment Certificate

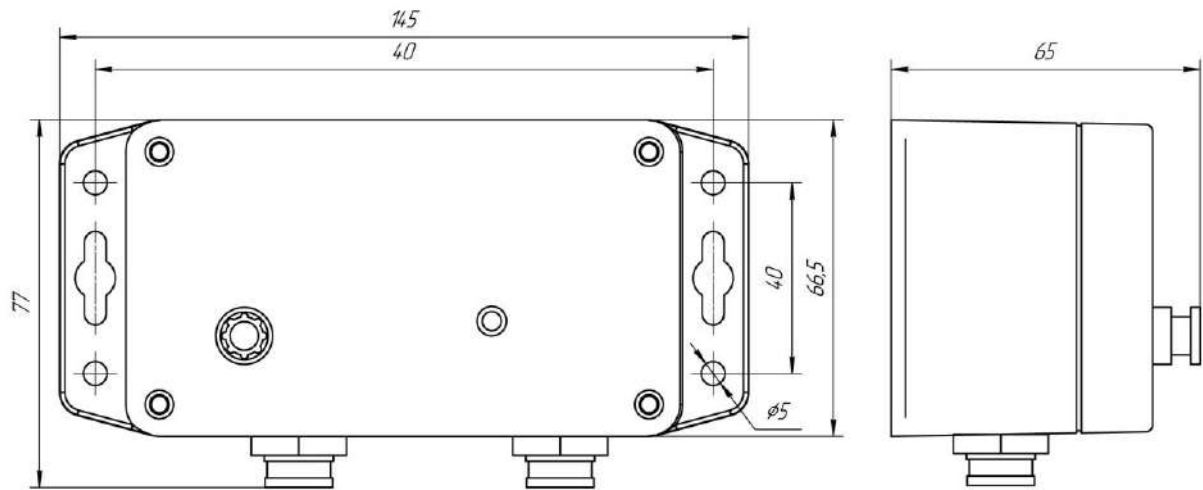

Fig. 2.6 – Overall and mounting dimensions of Power Adapter

2.22 Content of non-ferrous metals

Aluminum and aluminum alloys – 35 g

Copper and copper based alloys – 620 g

3 Scope of supply

3.1 Scope of supply:

| | |
|---|-------|
| ■ Meter KWH-Marsen (fixing cover incl.) | 1 pc. |
| ■ PSU ¹⁾ or Power Adapter ⁵⁾ | 1 pc. |
| ■ Shunt ²⁾ | 1 pc. |
| ■ Data Processing Module ⁶⁾ | 1 pc. |
| ■ RS232 or RS422 (RS485) Interface Board ⁶⁾ | 1 pc. |
| ■ RF module 433 MHz ⁶⁾ | 1 pc. |
| ■ Connection cables ⁴⁾ | 1 set |
| ■ Mounting Board ³⁾ | 1 pc. |
| ■ Equipment Certificate MC2.720.500 EC | 1 pc. |
| ■ Adjustment Manual MC2.720.500 A1 ⁶⁾ | 1 pc. |
| ■ Intermediate Maintenance and Repair Manual MC2.720.500 MR ⁷⁾ | 1 pc. |
| ■ MarsViewDC program and PC connection cable ⁸⁾ | 1 pc. |
| ■ Package | 1 pc. |

Notes

1 For the meter powered from the circuit under review

PSU in a protection enclosure is included in the scope of supply of the meter rated at 3000V, 300A (connected as a “sink” device)

2 Shunt 75-SC can be excluded from the scope of supply on customer request; Shunt 150-SC is optional

3 Optional

4 Optional for the meter rated at 3000V, 300A (connected as a “sink” device)

5 Can be added on customer request

6 Optional

7 Optional

8 Software for automatic adjustment of the meter, Operator’s Guide, Optical Port (IEC 61107-2001), Power Supply and PC connection cable can be supplied on order.

4 Design and operation principle

4.1 Block diagram is shown in Fig. 4.1.

4.2 The meter consists of the Measurement Module and built-in Voltage Divider mounted on the corresponding PCBs inside the plastic enclosure.

Optionally, the meter can include the Data Processing Module.

4.3 As a set of high-precision and high-stability resistors, the Voltage Divider interfaces the output voltage U_u (which is proportional to the measured voltage taken from the circuit under review U_{meas} or to the calibration voltage U_{cal} applied during calibration of the meter) with the voltage accepted by the Analogue-to-Digital Converters (ADCs).

The division factor of the Voltage Divider can be adjusted either with a variable resistor or potentiometer.

4.4 The Measurement Module consists of a microcontroller (which combines 3 independent ADCs), non-volatile memory, LCD, Pulse Output Module, built-in battery (as a back-up power supply) and Pulse Power Supply Module.

4.5. Voltage signals U_{i1} and U_{i2} (proportional to the measured current) are applied to the current measurement inputs of the ADCs and voltage signal U_u taken from the Voltage Divider's output and proportional to the measured voltage is applied to the voltage measurement input of the corresponding ADC. The Microcontroller measures these signals and calculates the consumed / generated energy. Each ADC calibration factor is stored in the non-volatile memory of the Microcontroller (checksum of the measurement program component is 0xA569, CRC16 0x8005 polynomial).

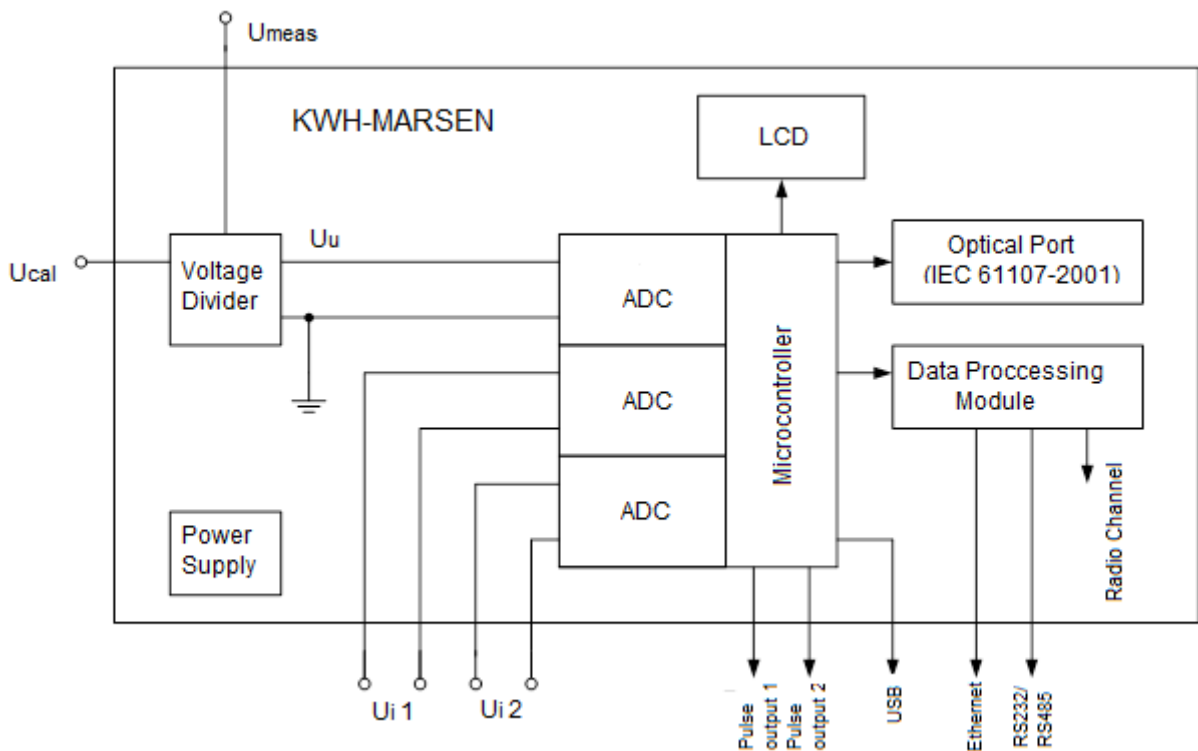

Fig. 4.1 – Block diagram of the meter

4.6 The Microcontroller saves the calculated value of energy into the memory in 1 s intervals and generates a sequence of n pulses (where n is proportional to the calculated value) on each pulse input.

In 2-directional mode, the values of consumed/generated energy are displayed alternately.

The back-up battery makes it possible to view readings of the meter when it is powered off.

The Measurement Module is equipped with the following interface ports:

- Optical port (IEC 61107)
- USB (virtual COM port)

4.7. The Data Processing Module makes it possible to record load profiles in customer-selected intervals (1s to 30 min).

The Data Processing Module has the following interface ports:

- Ethernet 10Base-T/100Base-TX
- RS232 or RS485/RS422
- Radio Module 433 MHz

4.8 Power supply voltage taken from an auxiliary circuit is directly or via Power Adapter or via PSU applied to the pulse Power Supply Module. The power supply voltages provided by the pulse PSM are galvanically isolated from the measurement circuit and auxiliary power supply circuit.

5 Storage, transportation and warranty conditions

5.1 Mean time to failure is at least 24000 hours.

5.2 Average lifetime is at least 15 years.

5.3 Transportation and storage

5.3.1 Utmost transportation conditions in the manufacturer's package:

- Ambient temperature -50 to 60 °C
- Relative humidity 95 % at 30 °C

5.3.2 The meter shall be transported packed in the individual customer package, and then in the special transportation box. The meter can be transported in enclosed wagons or vehicles protected from rain and snow or other enclosed vehicles including air-tight heated plane cargo compartments.

KWH-Marsen meters can be transported without individual packaging provided that the meters are stacked inside the transportation box in no more than 3 rows in height separated by full height, depth, width and perimeter dividers.

5.3.3 Storage conditions

KWH-Marsen meters shall be stored packed in their original packaging.

Storage conditions (in the original packaging):

- Ambient temperature 0 to 40 °C
- Relative humidity 80 % at 35 °C

Being stored on storeroom shelves in the original packaging, the meters shall be stacked in no more than 5 rows in height at a distance of at least 5 m from the heating system.

Storage conditions (without packaging):

- Ambient temperature 10 to 35 °C
- Relative humidity 80 % at 25 °C

Being stored on storeroom shelves without packaging, the meters shall be stacked in no more than 5 rows in height (each row separated by full height dividers) at a distance of at least 1 m from the heating system.

The storeroom should be free from corrosive dust, acid or alkali fumes and other aggressive substances.

Concentration limits of corrosive components in the air:

Sulfur dioxide gas – maximum 20 mg/(m²•day) (maximum 0.025 mg/m³)

Chlorides – 0.3 mg/ (m²•day)

5.4 Warranty

5.4.1. All of the Devices produced by the Manufacturer are warranted to conform to the specifications stated in the Equipment Certificate **for a period of 18 (eighteen) months** from the date of purchase. However the warranty period must not exceed 24 months from the date of manufacture including the storage and operation periods. The Device believed to be defective may be sent within the warranty period to the Manufacturer for inspection (the Warranty Claim enclosed, transportation prepaid). If the inspection carried out by the Manufacturer confirms that the Device is defective, it will be repaired or replaced (at the Manufacturer's option) at no charge, within the underlisted limitations (paragraph 5.4.3), and returned prepaid to the location specified in the buyer's Warranty Claim. All replaced parts become the property of the Manufacturer.

Conditions

5.4.2 In the event of any Device's failure or defect in manufacture or material during the warranty period (provided that the transportation, storage and operating conditions outlined in this Equipment Certificate are fulfilled), send the Device to the Manufacturer along with the sales invoice or other proof of the ownership and date of purchase. If the purchase documents are absent, the warranty period is calculated from the date of manufacture of the Device.

The Manufacturer retains the right to reject a warranty claim in the following cases:

- 1) Warranty Claim is filled out incompletely, incorrectly or illegibly
- 2) The Device has:
 - Serial number altered or removed or illegible
 - Evidence of mechanical impact on the enclosure and cover (cracks, scratches or other mechanical defects)
 - Evidence of short-circuiting (melted plastic, soot, etc.)
 - Broken seal with the calibrator's stamp

This warranty is not applicable for:

- 1) Damages to the Device caused during shipment to and from the Manufacturer's site.
- 2) Parts requiring regular maintenance or replacement due to natural wear
- 3) Consumable parts (parts, the nature of which is to become worn or depleted with use, such as batteries)
- 4) Damages to the Device caused by:
 - a) Any use other than correct use described in the Equipment Certificate including:
 - Handling of the Device resulting in mechanical damages or other defects including any changes or modifications to the Device, or damages to the LCD
 - Installation or use of the device in a manner inconsistent with the technical and safety laws or standards in force in the country where it is installed or used
 - Any maintenance other than correct maintenance described in the Equipment Certificate
 - b) Computer virus infection or use of the Device with the software not provided with the Device, or incorrectly installed software
 - c) Damages caused by condition or defects of a system or its elements with which or as part of which the Device was used, excluding the other Manufacturer's products intended for use with the Device
 - d) Damages caused by accessories or ancillary equipment not made or authorized by the Manufacturer with respect to their type, condition or characteristics

e) Damages caused by repairs or attempts to repair the Device executed by an unauthorized person or company

f) Damages caused by adjustments or modifications made to the Device without prior written consent of the Manufacturer

g) Damages caused by negligent handling

h) Damages caused by accidents, fire, ingress of liquids, chemicals or other materials, flood, vibration, heat, improper ventilation, variations of supply voltage, improper power supply or input voltage, electrostatic discharge including lightning, or any other impacts or external actions beyond the reasonable control of the Manufacturer and not covered by the technical documentation for the Device

The present warranty only covers hardware failures. This warranty does not cover failures of software (produced either by the Manufacturer or by third parties), which are the subject of express or implied end user license agreements, separate warranties, or exclusions.

5.4.3 The Manufacturer establishes the lifetime for the products outlined above (excluding the batteries) of 4 (four) years from the date of purchase from the Manufacturer. The lifetime period for the batteries is 2 (two) years from the date of purchase from the Manufacturer. *Please note that the warranty period and lifetime differ from each other.*

5.4.4 It is highly recommended to make a backup copy of the data from the Device's internal memory and store it on another (external) media. The Manufacturer shall in no circumstances be liable for any direct or indirect damages or losses, whether incidental, consequential or otherwise, including but not limited to loss of profits, loss of use or any deletion, corruption, destruction or removal of data, disclosure of confidential information or infringement of privacy, data recovery expenses, losses arising out of interruption of commercial, production or other activities based on use or loss of use of the Device.

Manufacturer's address (for warranty claims):

Russia

OOO NPP Mars-Energo

V.O. 13 Line 6 - 8, office 41H, St. Petersburg

Tel: +7 812 327-21-11; +7 812 331-87-35

E-mail: mail@mars-energo.ru

www.mars-energo.com

Estonia

ESME OU

Kadastiku 25a, Narva, Estonia 21004

Tel: +372 56809999

E-mail: mail@esme.ee

6 Operation

6.1 Mounting and preparing for operation

6.1.1 KWH-Marsen meters must be mounted in the locations that are free from aggressive fumes and comply with the environmental requirements specified in section 1.3.

6.1.2 KWH-Marsen meters must be mounted inside protective cabinets to protect them from contamination and mechanical damage if any are possible.

6.1.3 KWH-Marsen meters rated at 800V or above must be mounted on insulators in a way that makes it impossible to reach or touch them by accident (e.g. inside high-voltage protective cabinets).

6.1.4 The meter is assembled inside a plastic protection enclosure. The front panel bears:

- LCD
- LEDs of pulse outputs
- Nameplate with meter constants and other meter data
- Optical port
- Buttons for controlling the LCD
- LEDs of interface ports
- Interface Module nameplate

The bottom part of the panel is occupied by the terminal block including:

- Terminal cover sensor
- USB port
- Terminals of pulse outputs 1 and 2
- Terminals of RS232 / RS422 (RS485) interface ports
- Terminals for connecting power supply and signals from the circuit under review

6.2 Indicators and connection terminals

Fig. 6.2.1 and Fig. 6.2.2 show the meter, its indicators and connection terminals.

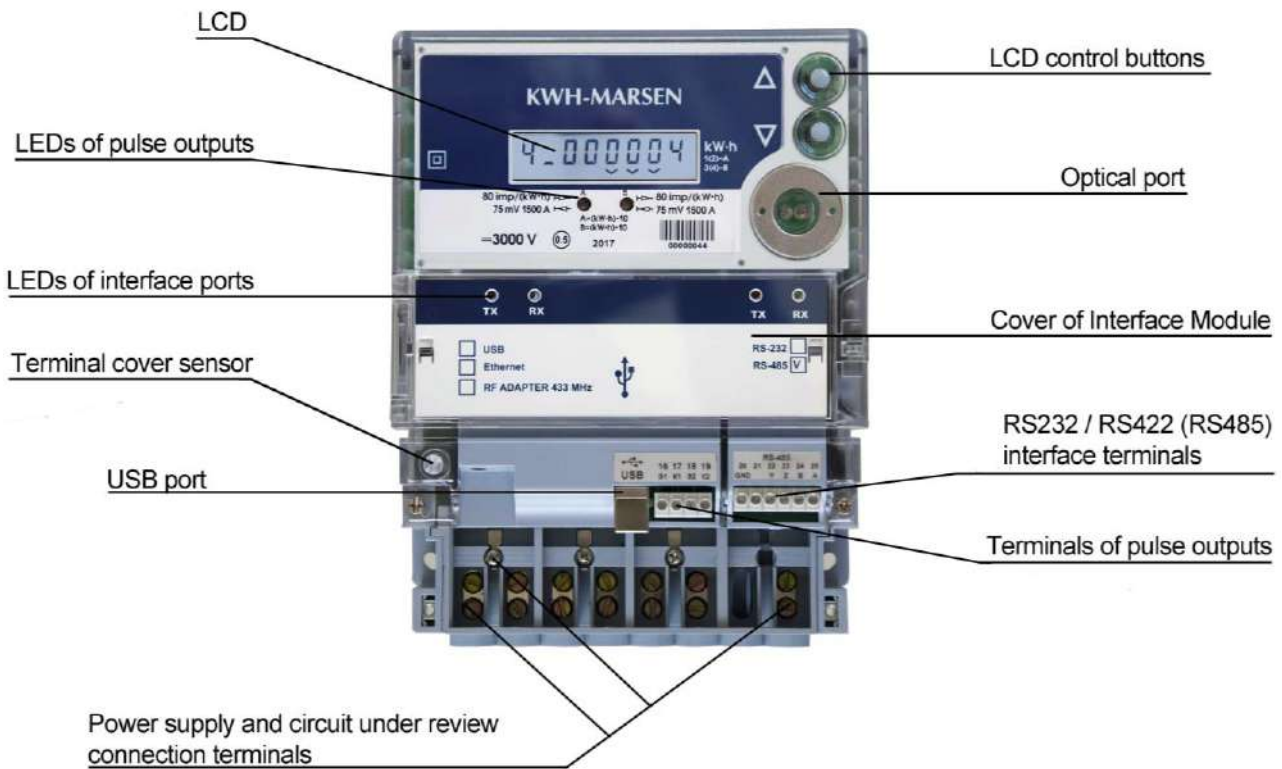

Fig. 6.2.1 – View of the meter with the terminal cover removed

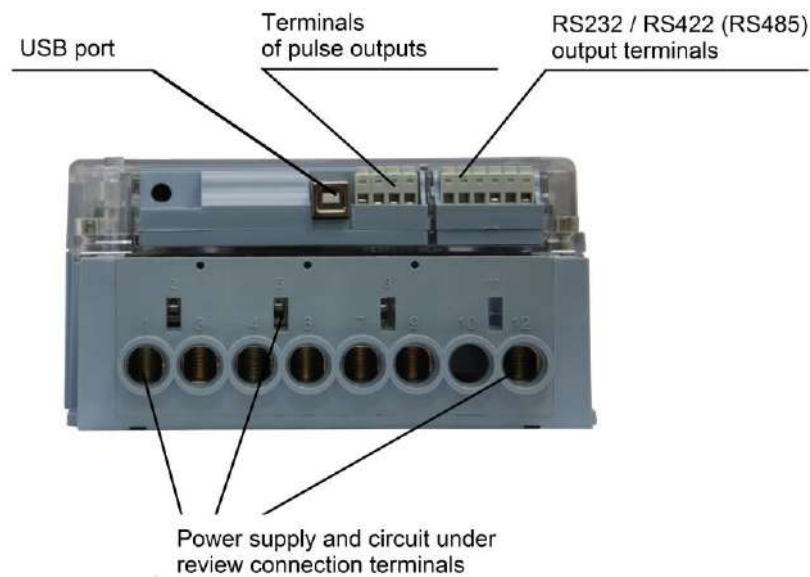

Fig. 6.2.2 – View of terminals and connectors

6.2.1 The back-up power supply of the meter: battery ER14505 (battery life is 6 years). It provides data indication when the meter is powered off.

6.2.2 Data indication is as follows:

- Firmware version (2-digit format of version number)
- Voltage, V (U)
- Current in Channel 1, A (I1)

Equipment Certificate

- Current in Channel 2, A (I2)
- Power in Channel 1, kW (P1)
- Power in Channel 2, kW (P2)
- Energy consumption (forward direction) in Channel 1 (1_)
- Energy generation (reverse direction) in Channel 1 (2_), only for bidirectional meters)
- Energy consumption (forward direction) in Channel 2 (3_)
- Energy generation (reverse direction) in Channel 2 (4_), only for bidirectional meters)
- Temperature inside the meter (inside the measuring IC), °C
- Date in DD-MM-YY format
- Time in HH-MM-SS format
- Diagnostic error code (e.g. Err 1, where 1 – error number)

Parameters to be indicated and indication time is set via serial port and stored in the memory of the meter.

6.2.3 In the absence of the external power supply, the calculated values of energy are displayed in 10 s intervals (complete with attributes 1_, 2_, 3_, 4_) provided that these parameters were set for indication.

6.2.4 The meter displays events indicated as ‘V’ symbol on the LCD. The events are identified by the position of ‘V’ symbol:

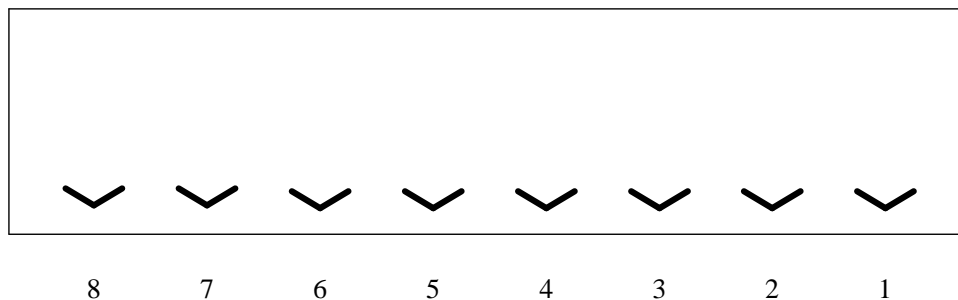

Fig 6.2.3 – Position-dependent event indication

Table 6.2.1 – Indicated events

| Position number | Meaning | Notes |
|-----------------|---|--------------------------------|
| 1 | Battery failure | Replace the battery |
| 2 | Power supply failure – the meter goes to Sleep mode | Check power supply connections |
| 3 | The Interface Module cover was opened. | Unauthorized access |
| 4 | The Terminal Board cover was opened | Unauthorized access |
| 5 | USCI_A0 – OPTOPORT interface is active | Data exchange |
| 6 | USCI_A1 – WIRE interface is active | Data exchange |
| 7 | Data Processing Module is absent | |
| 8 | Calibration jumper is placed | Remove the jumper |

Table 6.2.2 – Indicated errors

| Error identifier | Meaning | How to correct | The meter should be |
|------------------|--|--|---------------------|
| Err 1 | Checksum error (Flash MSP430 Segment A or B) | Full reset of the microcontroller | Sent for repair |
| Err 2 | Interface I2C error | Repair | Sent for repair |
| Err 3 | Incorrect data in FRAM | Full reset of the microcontroller | Sent for repair |
| Err 4 | Oscillator error | Repair | Sent for repair |
| Err 5 | Incorrect checksum of energy data collected in RAM | Connect the meter to an external power supply for a short time | |
| Err 6 | Checksum error (Flash MSP430 Segment C or D) | Full reset of the microcontroller | Sent for repair |
| Err 7 | Checksum error (Flash MSP430) | Firmware replacement | Sent for repair |

6.2.5 With the Data Processing module, pins of the interface ports function as follows:

| Interface port \ number of the pin | 20 | 21 | 22 | 23 | 24 | 25 |
|------------------------------------|-----|-----|-----|----|----|------|
| RS232 | GND | --- | --- | RX | TX | ---- |
| RS422 (RS485) | GND | --- | Y+ | Z- | B- | A+ |

Note

For RS485 interface, pins 22 and 25 as well as pins 23 and 24 must be short-circuited.

6.3 Examples of connecting the meter to the circuit under review

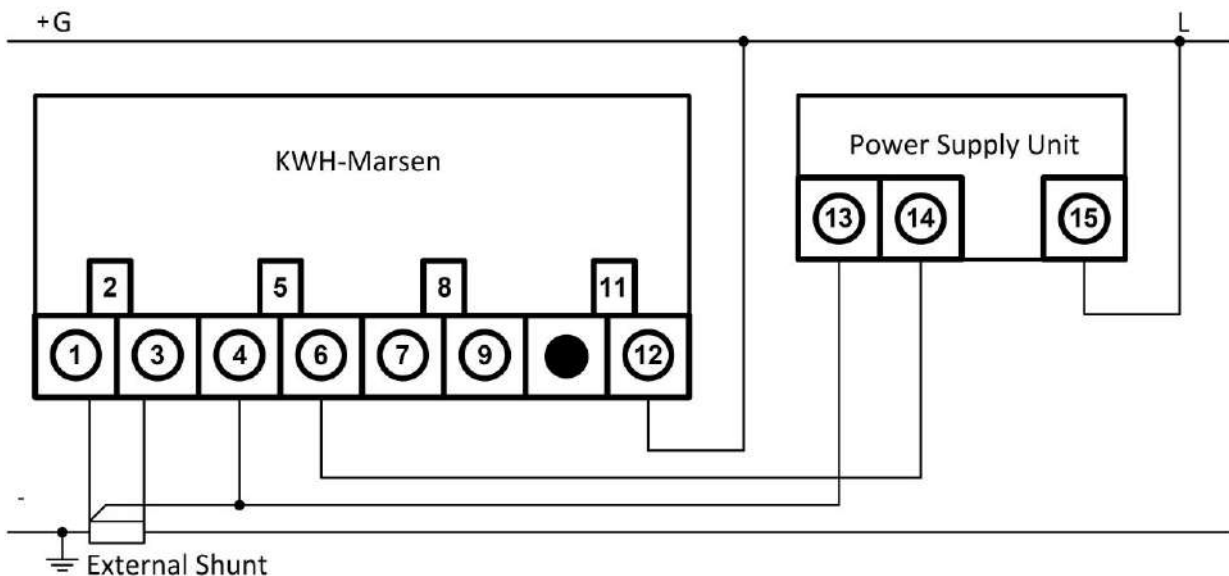

G –Generator, L –Load

Fig. 6.3.1 - KWH-Marsen connected as a sink input device (Shunt is connected in series with “minus” conductor)

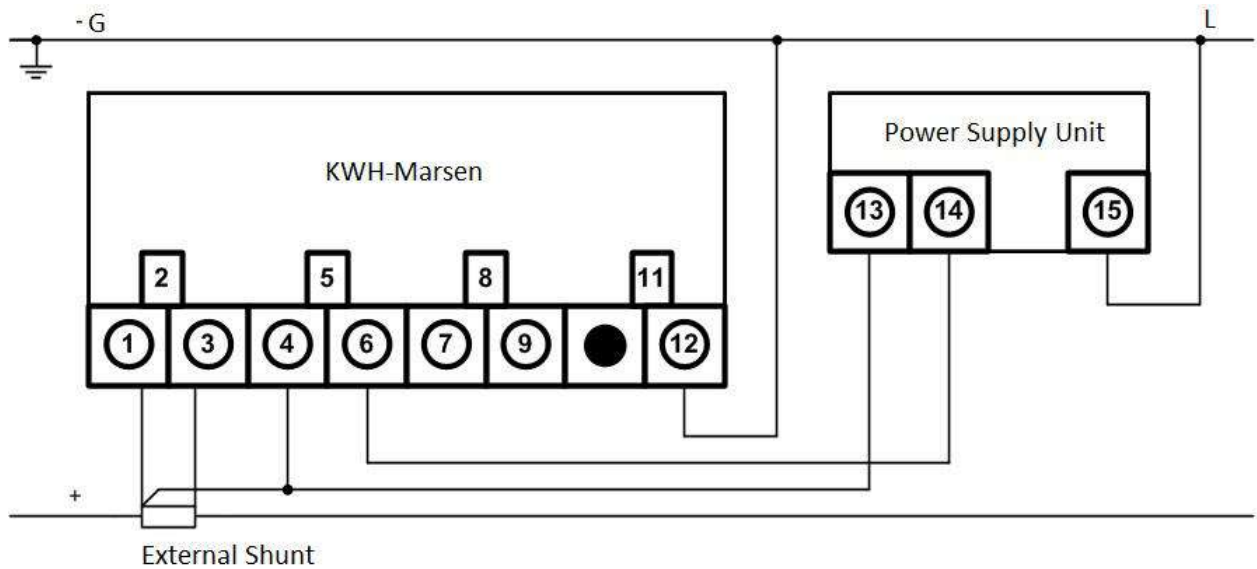

G –Generator, L –Load

Fig. 6.3.2 - KWH-Marsen connected as a source input device
(Shunt is connected in series with “plus” conductor)

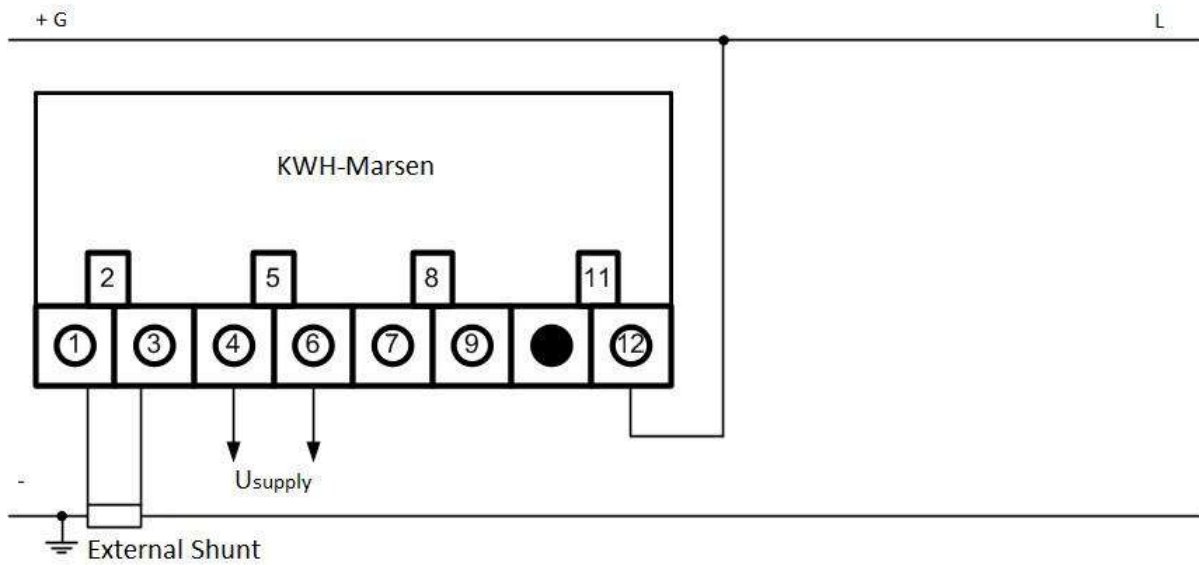

G –Generator, L –Load

U_{supply} – power supply voltage from auxiliary AC or DC network
(connected to terminals 4 and 6 without considering the polarity)

Fig. 6.3.3 - KWH-Marsen powered
from an auxiliary network and connected as a sink input device
(Shunt is connected in series with “minus” conductor)

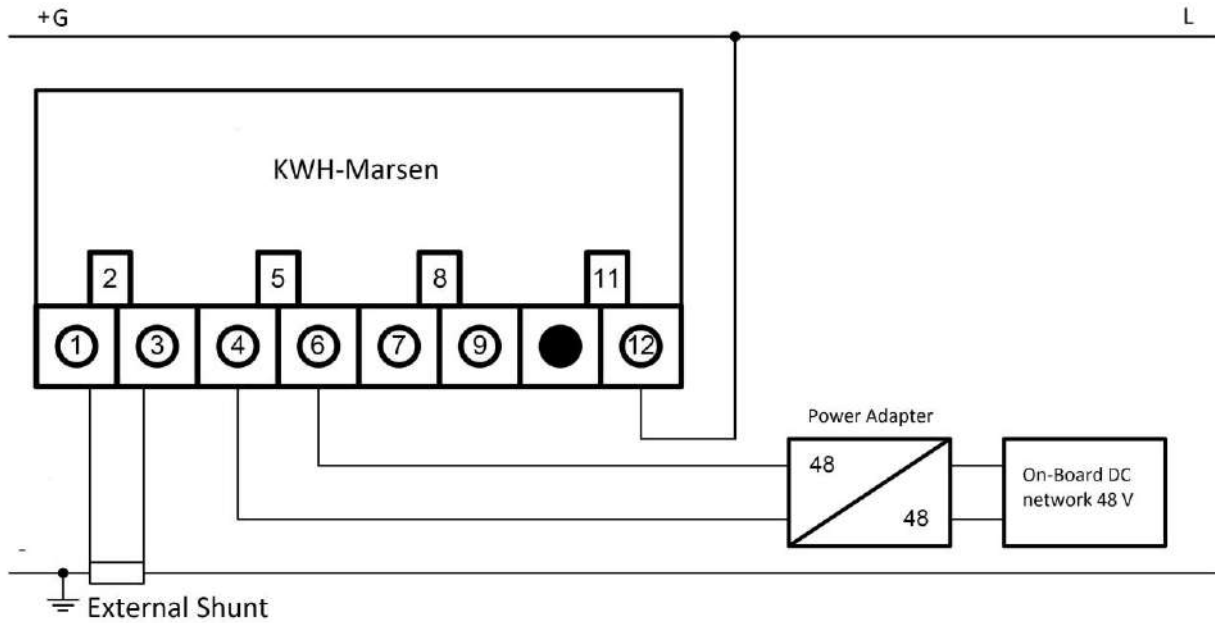

G –Generator, L –Load

Power adapter – HV Galvanic Insulation Module for powering the meter from an on-board DC network 48 V (option 1) or on-board DC network 110 V (option 2) (connected to terminals 4 and 6 without considering the polarity)

Fig. 6.3.4 - KWH-Marsen powered from an auxiliary network and connected as a sink input device (Shunt is connected in series with “minus” conductor)

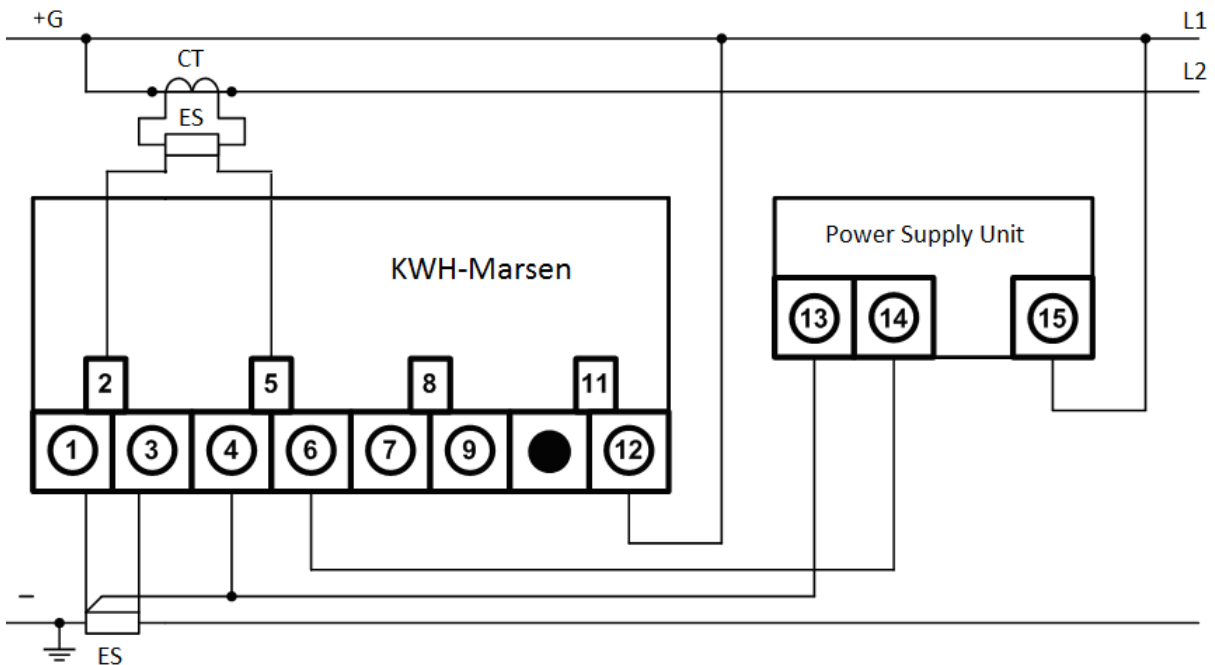

G – Generator, L1 – Load 1, L2 – Load 2, CT – Current Transformer

ES – External Shunt (terminals 1, 3 – Channel 1; terminals 2, 5 – Channel 2)

Fig. 6.3.5 - KWH-Marsen (2-channel configuration) connected as a sink input device (Shunts are connected in series with “minus” conductor)

7. Maintenance and safety requirements

7.1 Keep the meter and its power supply unit free of foreign objects. The meter and power supply unit must not be exposed to shocks or jolts.

7.2 While the meter is being installed or calibrated or used as intended, the “Interbranch rules for Labour Safety (Safety Rules) When Operating Electrical Systems” and local electrical safety requirements must be observed.

7.3 If the meter needs to be cleaned, use a cloth slightly moistened with a mild detergent.

8. Calibration procedure

8.1 KWH-Marsen meter, serial N _____

The meter’s calibration procedure shall be carried out in compliance with the calibration methods established by D.I. Mendeleev Institute for Metrology (VNIIM, Saint-Petersburg, Russia). The meter undergoes primary post-manufacture calibration, and then it is calibrated after each repair. Regular calibration is performed during operation.

A period of 3 (three) calendar years is considered maximum time between calibrations. The next regular calibration is carried out regardless of whether the meter was in use or not.

8.2 The summary results of calibration are entered in Table 8.2.

Table 8.2

| Date of calibration | Type of calibration | Calibration results (pass / fail) | Calibrator’s signature and Name | Date of next calibration |
|---------------------|---------------------|-----------------------------------|---------------------------------|--------------------------|
| | | | | |
| | | | | |
| | | | | |
| | | | | |
| | | | | |
| | | | | |
| | | | | |

| Date of calibration | Type of calibration | Calibration results (pass / fail) | Calibrator's signature and Name | Date of next calibration |
|---------------------|---------------------|--------------------------------------|---------------------------------|--------------------------|
| | | | | |
| | | | | |
| | | | | |
| | | | | |
| | | | | |
| | | | | |
| | | | | |
| | | | | |
| | | | | |
| | | | | |
| | | | | |
| | | | | |
| | | | | |
| | | | | |
| | | | | |
| | | | | |
| | | | | |
| | | | | |
| | | | | |

9. Acceptance form

DC energy meter KWH-Marsen N_____

Rated voltage _____ V, rated current (Channel 1) _____ A, Rated current (Channel 2) _____ A,

Shunt (Channel 1) rated at 150 mV 75 mV

Shunt (Channel 2) rated at 150 mV 75 mV

Energy measurement (Channel 1) generation and consumption consumption

Energy measurement (Channel 2) generation and consumption consumption

Power supply _____

Serial N _____

Manufacturer: OOO “NPP Mars-Energo”

Date of manufacture _____ 20

has been manufactured in compliance with Technical Specifications TS 4228-038-49976497-2013, sealed with Calibrator’s stamp and approved as ready for use.

(Corporate Seal) _____ (Signature and Name)

10. Packing form

DC energy meter KWH-Marsen N_____ has been packed by OOO “NPP Mars-Energo” in compliance with the Corporate Technical Requirements in force.

Scope of supply:

- | | |
|--|--|
| <input type="checkbox"/> PSU (BUP) | <input type="checkbox"/> PP |
| <input type="checkbox"/> Shunt _____ A; _____ mV | <input type="checkbox"/> Shunt _____ A; _____ mV |
| <input type="checkbox"/> Data Processing Module | <input type="checkbox"/> RS232 |
| <input type="checkbox"/> RS422/485 | <input type="checkbox"/> USB |
| <input type="checkbox"/> USB + RF Module 433 MHz | |
| <input type="checkbox"/> USB + Ethernet | |
| <input type="checkbox"/> Mounting Board | |
| <input type="checkbox"/> Set of cables | |
| <input type="checkbox"/> Equipment Certificate | |
| <input type="checkbox"/> Adjustment manual | |
| <input type="checkbox"/> Repair guide | |
| <input type="checkbox"/> MarsViewDC software and PC connection cable | |